

This Application Note applies to Quantum MP series drives

Using the Quantum MP with 24 Vdc PLC Control

The differences between the Quantum MP and the Mentor MP are that the Quantum MP has built in fuses, motor contactor and 120 Vac inputs for controlling the drive. There are applications where the control logic needs to be 24 Vdc when controlling the drive with a PLC, for example, but still require the fusing and motor contactor provided in the Quantum MP. Below is a diagram of the default Control Logic for the Quantum MP and the associated parameter changes.

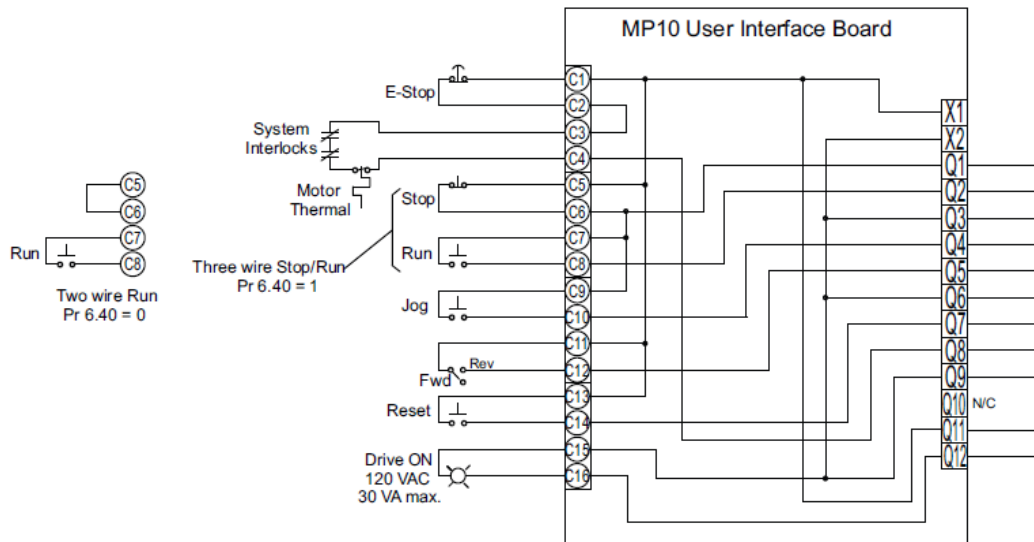

Parameter	QMP Value	Description
5.16	1	Selects Armature Voltage from motor side of the contactor
6.40	1	Enable sequencer latching
8.22	0.00	Disable T25 digital I/O 2 source / destination on Mentor MP
8.23	0.00	Disable T26 digital I/O 2 source / destination on Mentor MP
8.24	0.00	Disable T27 digital I/O 2 source / destination on Mentor MP
8.26	0.00	Disable T29 digital I/O 2 source / destination on Mentor MP
9.04	17.06	External Trip input from e-stop / system interlock loop – C4 input (120 Vac)
9.05	1	Logic Function 1 - Invert Terminal C4
9.09	0.1	Logic Function 1 - Time delay for external trip input
9.10	10.32	Logic Function 1 - Destination of C4 Input (external trip)
9.37	1	Set Logic Function 1 to “OR” gate
17.21	6.39	T1 SM-I/O 120 digital input destination – Not Stop
17.22	6.34	T2 SM-I/O 120 digital input destination – Run
17.23	6.31	T4 SM-I/O 120 digital input destination – Jog
17.24	6.33	T5 SM-I/O 120 digital input destination – Forward / Reverse
17.25	10.33	T7 SM-I/O 120 digital input destination – Drive reset
17.28	6.55	Relay 2 source – Contactor enable

In this particular application note we will re-configure the drive to use 24 Vdc logic for the Run, Stop, Jog and the Fwd/Reverse control inputs. It is assumed that these functions will be controlled by a PLC, the remaining functions will be left as 120 Vac inputs since the E-Stop, System Interlocks and the Reset are typically signals / controls that are outside of the control cabinet and for good noise immunity are better left as 120 Vac control. Our new 24 Vdc control inputs will now be made at the control terminal strip on the Mentor MP portion of the Quantum MP.

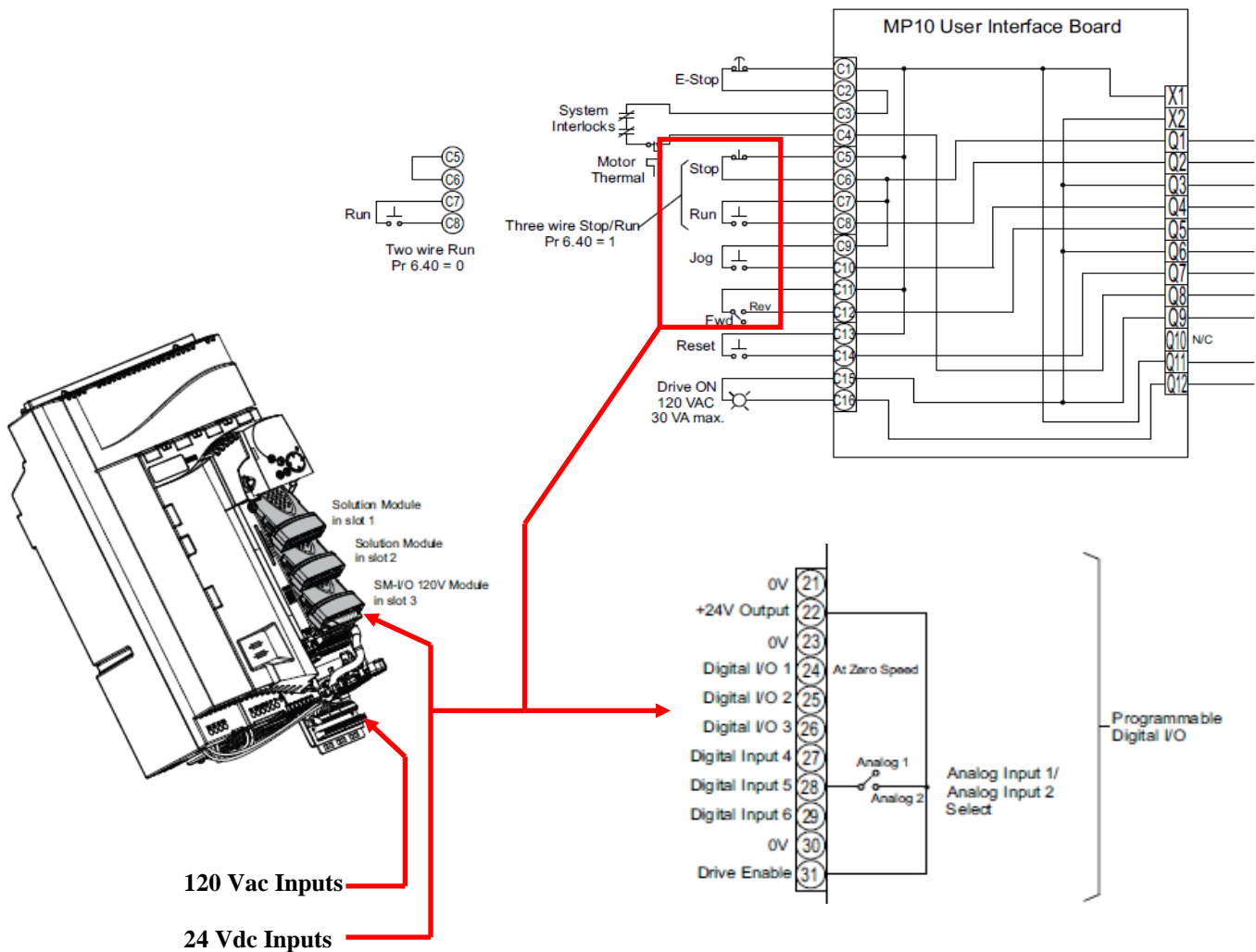



No wiring changes will be required between the M10 User Interface board and the SM-I/O 120 V, only parameter changes shown below.

Parameter	QMP Value	Description
8.22	6.39	Disable T25 digital I/O 2 source / destination on Mentor MP – Not Stop
8.23	6.34	Disable T26 digital I/O 2 source / destination on Mentor MP – Run
8.24	6.31	Disable T27 digital I/O 2 source / destination on Mentor MP – Jog
8.26	6.33	Disable T29 digital I/O 2 source / destination on Mentor MP – Forward / Reverse
17.21	0.00	T1 SM-I/O 120 digital input destination
17.22	0.00	T2 SM-I/O 120 digital input destination
17.23	0.00	T4 SM-I/O 120 digital input destination
17.24	0.00	T5 SM-I/O 120 digital input destination
6.40	1	Sequencer Latching enable

Three Wire Control

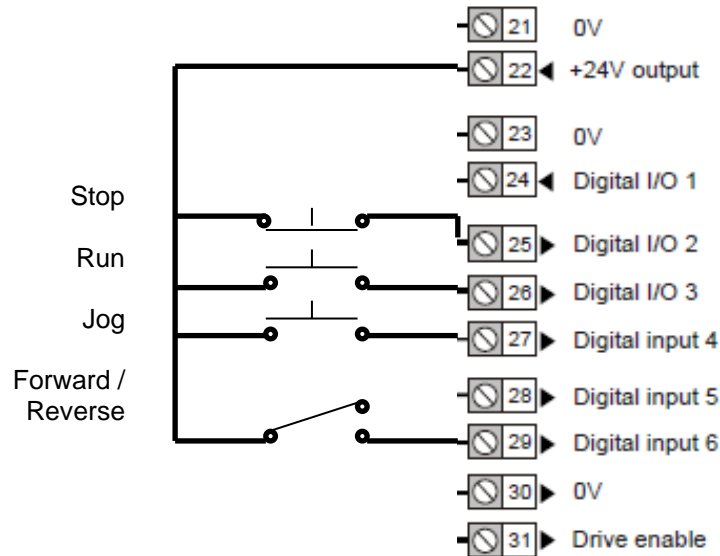

Two Wire Control (PLC)

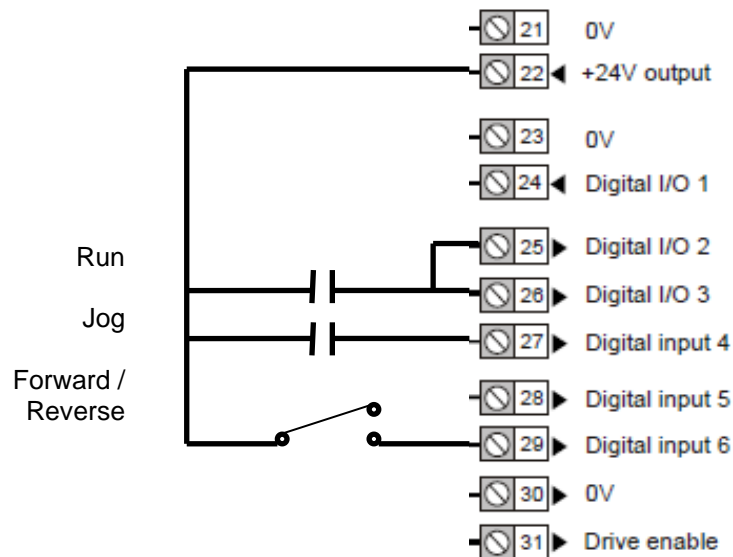

Resources: can be found on our website: www.controltechniques.com

For help contact techsupport.cta@mail.nidec.com, or
call Technical Support at 952-995-8000, 24/7/365