

This Application Note applies to all Unidrive M series

Negative Logic Control

This document provides information on how to set up Unidrive M Series for negative logic applications. Unidrives M400 – M702 have the ability to select between positive and negative logic using a parameter. For the M400 - Parameter 08.010, Input Logic Polarity, 0 for Negative logic and 1 (Default) for Positive Logic. For the M600 – M702 Parameter 08.029, Input Logic Polarity, 0 for Negative logic and 1 (Default) for Positive Logic. For the Unidrive M300 – M702, the Safe Torque Off (STO) inputs cannot be converted into negative logic.

Negative Logic Control For the M100 – M300

Unidrive M100-M300 does not have negative logic as standard, although it is possible to set this up by using some external pull up resistors and by changing some parameters.

Parameter Changes

Before making any changes to the drive for the specific application, the drive should be able to run using the Keypad mode (#00.005 = **Pad**) to verify proper operation of the drive and motor shaft rotation. This involves entering the basic motor information and a connection between terminals 9 and 11. Once the drive is verified then stop the drive from running. Remove the connection between terminals 9 and 11 then set the drive up via parameters #00.005 (reference control) and #06.004 (start/stop logic) and also make the following changes in the chart below.

Terminal	Parameter	Setting
Terminal 11	#08.012	On/Invert
Terminal 12	#08.013	On/Invert
Terminal 13	#08.014	On/Invert
Terminal 14*	#08.015	On/Invert

*M200-M300 only

Take time to save the parameters in the drive or the changes that were made will become deleted and will have to be re-entered again if power is shut off to the drive. Go to parameter #00.000 and change the setting to **“SAVE”**, or by entering **“1000”**, then press the red stop/reset button once; the setting should then return to **“None”** representing all the parameters in the drive are saved.

Resistor Connections

Resistors used is 3.9kΩ, ¼ W.

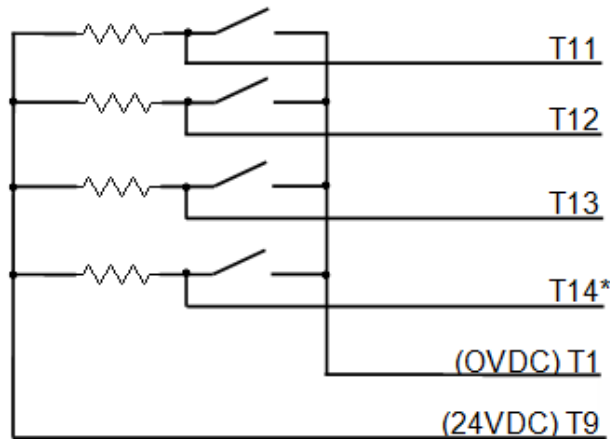

*Terminal 14 is not available on M100/M101



Drive Operation

Connecting the resistors pulls the digital input terminal up to about 12.75 Vdc with the 24 Vdc at its lowest voltage tolerance.

With the given changes and with the switches open the voltage on terminals is above the switching threshold voltage that makes the terminal inactive. When the switch is closed the terminal is connected to the 0 Vdc common and below the threshold voltage making the terminal active.

If a 24 Vdc overload fault (**O.Ld1**) code appears then shut off power to the drive immediately. Test the terminal operation to verify the drive goes from Inhibit mode (Inh) or Ready mode (Rdy) to the run mode. This can be done without a motor connected to the drive as long as parameter #00.041 is set to “Fd” (Fixed Boost).

Resources: can be found on our website: www.controltechniques.com

For help contact techsupport.cta@mail.nidec.com, or call Technical Support at 952-995-8000, 24/7/365